

Wednesday, August 9, 2017

Revision 1: Dated March 20th, 2018 – added the 10,000 and 24,000 lbs D-ring

Attn: ASAs, REPs, and Rental Equipment customers

RE: Lift (D-ring) Ring bulletin for rental products

Many Smart Family of Cooling Products are designed with an overhead lifting option. The overhead lifting option is typically done in the form of a D-Ring (also referred to as a lift or hoist ring).

The hoist rings are secured with a mounting bolt. The torque spec for the bolt as noted below based upon the rating of the D-ring.

5,000 lbs rated D-ring: the torque spec is **100 ft/lbs**. It is the factories recommendation that the customer check the torque setting of each lift ring prior to each lift. Again, prior to lifting (every-time) all 4 lift ring bolts should be torqued to 100 ft/lbs.

10,000 lbs rated D-ring: the torque spec is **230 ft/lbs**. It is the factories recommendation that the customer check the torque setting of each lift ring prior to each lift. Again, prior to lifting (every-time) all 4 lift ring bolts should be torqued to 230 ft/lbs.

24,000 lbs rated D-ring: the torque spec is **800 ft/lbs**. It is the factories recommendation that the customer check the torque setting of each lift ring prior to each lift. Again, prior to lifting (every-time) all 4 lift ring bolts should be torqued to 800 ft/lbs.

Below are photos depicting various rental units and their lift rings (for reference).



All lift rings are 5:1, Magnetic Particle Inspected Per ASTM 1444, Minimum tensile strength of 180,000 psi, Hoist Rings retain the same rated load from 0 to 90 degrees from the bolt axis .

SMART FAMILY OF COOLING PRODUCTS

www.SmartCoolingProducts.com



1118 First Street E, Humble TX 77338 p. 281.540.2805 / F. 281.540-8847

Smart Family can provide a data sheet for any lift ring used upon request. Smart Family can also provide a certificate of compliance for the lift rings, as well as a sample destruct report. If there are any additional questions, please contact technical support at (281) 540-2805.

Sincerely,

Ryan M Baker
VP Equipment Sales

Smart Family Service Bulletin

2016 Bulletin

Service Bulletins are designed to improve the overall reliability and dependability of all Smart Family units. It is recommended that only properly trained industry technicians work on Smart Family equipment and all standard safety practices be maintained.



Hoist Ring SAFETY INSTRUCTIONS

CAUTION: PRIOR TO USING ANY HOIST RING, PLEASE READ THE FOLLOWING FOR PROPER INSTALLATION AND USAGE.

As with all mechanical devices, regular inspection for wear and strict adherence to use instruction is necessary to prevent misuse failure.

- Despite the 5:1 safety factor, NEVER EXCEED THE RATED LOAD CAPACITY. This safety margin is needed in case of misuse, which could drastically lower load capacity.
- Tighten mounting screws to recommended torque. Periodically check torque because screws could loosen with extended service.

- Tensile strength of parent material should be above 80,000 PSI to achieve full load rating. For weaker material, consider through-hole mounting with a nut and washer on the other side.
- AVOID SHOCK LOADING. Always lift gradually. Repeat magnetic particle inspection if shock loading ever occurs.

• After installation, always check that ring rotates and pivots freely in all directions.

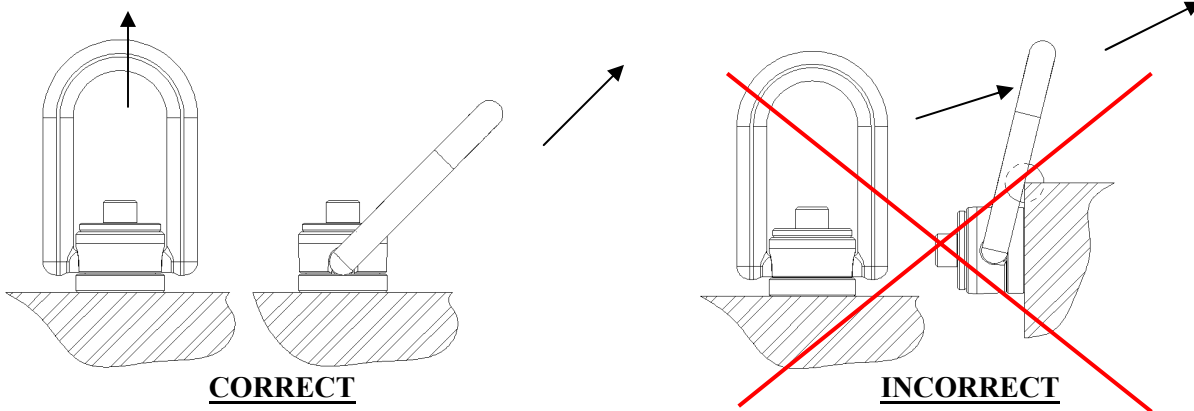

IMPORTANT! The force on each hoist ring is not just the total weight divided by the number of hoist rings. The force will be greater at lower lift angles. Make sure load is evenly distributed. See below.
Formula with example data: $F = \frac{W}{N \sin A}$

F = Force on each hoist ring
W = Total weight = 4000 lbs.
N = Number of hoist rings = 4
A = Lifting angle

Safe
Fig. 1

$$A = 65^\circ$$

$$F = 4000 / 4 \sin 65^\circ = 1103 \text{ lbs.}$$

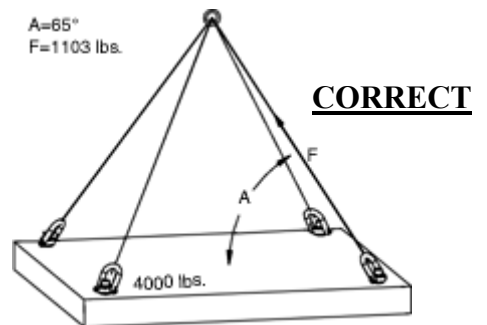

Unsafe
Fig. 2

$$A = 14^\circ$$

$$F = 4000 / 4 \sin 14^\circ = 4134 \text{ lbs.}$$

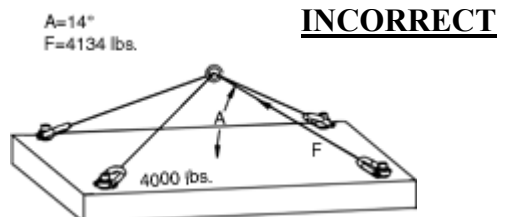

2. Never exceed the rated load capacity of the hoist ring.
3. Tensile strength of material to be lifted should be at least 80,000 PSI for full load rating. For lower tensile materials, increase thread length or use a through hole with a nut and washer on other side.
4. Do not allow hoist rings to bind. If necessary use a spreader bar to avoid binding. See example below.

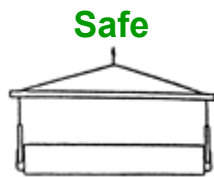

5. Spacers should not be used between the hoist ring and the mounting surface.
6. Mounting surface must be flat and smooth for full contact with the safety hoist ring. Tapped mounting holes must be perpendicular to the mounting surface.
7. Mounting screws should be tightened to the recommended torque. Torque should be checked periodically as bolts could loosen in extended service.
8. Never lift with any device, such as hooks, chains or cables that could spread or damage the bail.
9. Never apply shock loads and use good lifting practices. Always lift gradually. If shock loading ever occurs, the safety lifting device should be magnetic particle inspected.
10. After installation, always check that ring rotates and pivots freely in all directions.

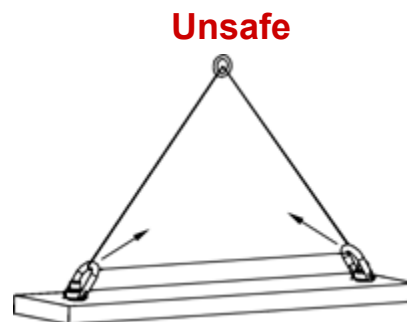
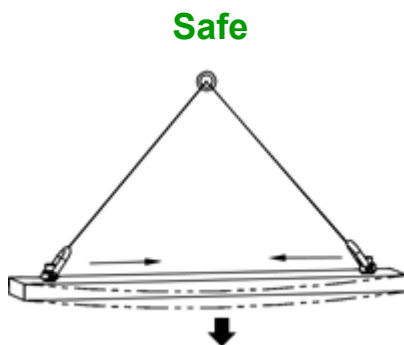

After slings have been properly attached to the hoist ring, apply force slowly. Make sure the bail is parallel to the direction of the load. Watch the load and be prepared to stop applying force if the load starts buckling.

Slings should not be reeved from one bail to another.



Certificate of Compliance

ADB® HEAVY DUTY® WELD MOUNT HOIST RINGS

ADB®'s QUALITY SYSTEM IS REGISTERED TO ISO 9001-2008

The material used in our ADB® Heavy Duty® Weld Mount Hoist Ring Components is AISA-SAE 4140 or equivalent and conforms to AMS-6382 and ASTM A 322.

CHEMICAL ANALYSIS

Carbon	.38/.43	Silicon	.15/.35
Manganese	.60/.85	Chromium	.90/1.20
Phosphorus	.030/Max	Molybdenum	.15/.30
Sulfur	.030/Max		

ADB® Heavy Duty® Weld Mount Hoist Rings are designed with a design factor of five times the rated capacity based in any lifting direction. However, the user is reminded that it should not be used to lift loads that exceed the rated capacity.

If any component or components of the hoist ring is replaced with a non-ADB® component, this certification is void.

ADB® Heavy Duty® Weld Mount Hoist Rings are designed to exceed the following military specifications and ASME standards:

MIL-STD-1365	General design criteria for handling equipment associated with weapons systems.
MIL-STD-209	Slinging and tie down provisions for lifting and tying down military equipment.
ASME B30.26	Safety Standards for cableways, cranes, derricks, hoists, hooks, Jacks and slings.

- The surface finish of ADB® Heavy Duty® Weld Mount Hoist Rings is Black Oxide per MIL-DTL-13924.
- ADB® Heavy Duty® Weld Mount Hoist Rings are magnetic particle inspected in accordance with ASTM E 1444.
- ADB®'s Heavy Duty® Weld Mount Hoist Rings are not exposed to any equipment or material known or suspected of having Mercury or Polychlorinated Biphenyls (PCB's).
- ADB® Heavy Duty® Weld Mount Hoist Rings are heat treated to 36-48 Rc per MIL-H-6875.
- Screws and stud assemblies are produced from 180,000 PSI minimum tensile strength material.

W.A.

Wes Anderson
Quality Assurance and Engineering

5740 Hunt Rd. Valdosta, GA 31606
(229) 253-8928 1-800-423-4425 Fax: (229) 253-8929
www.adbhoiststrings.com

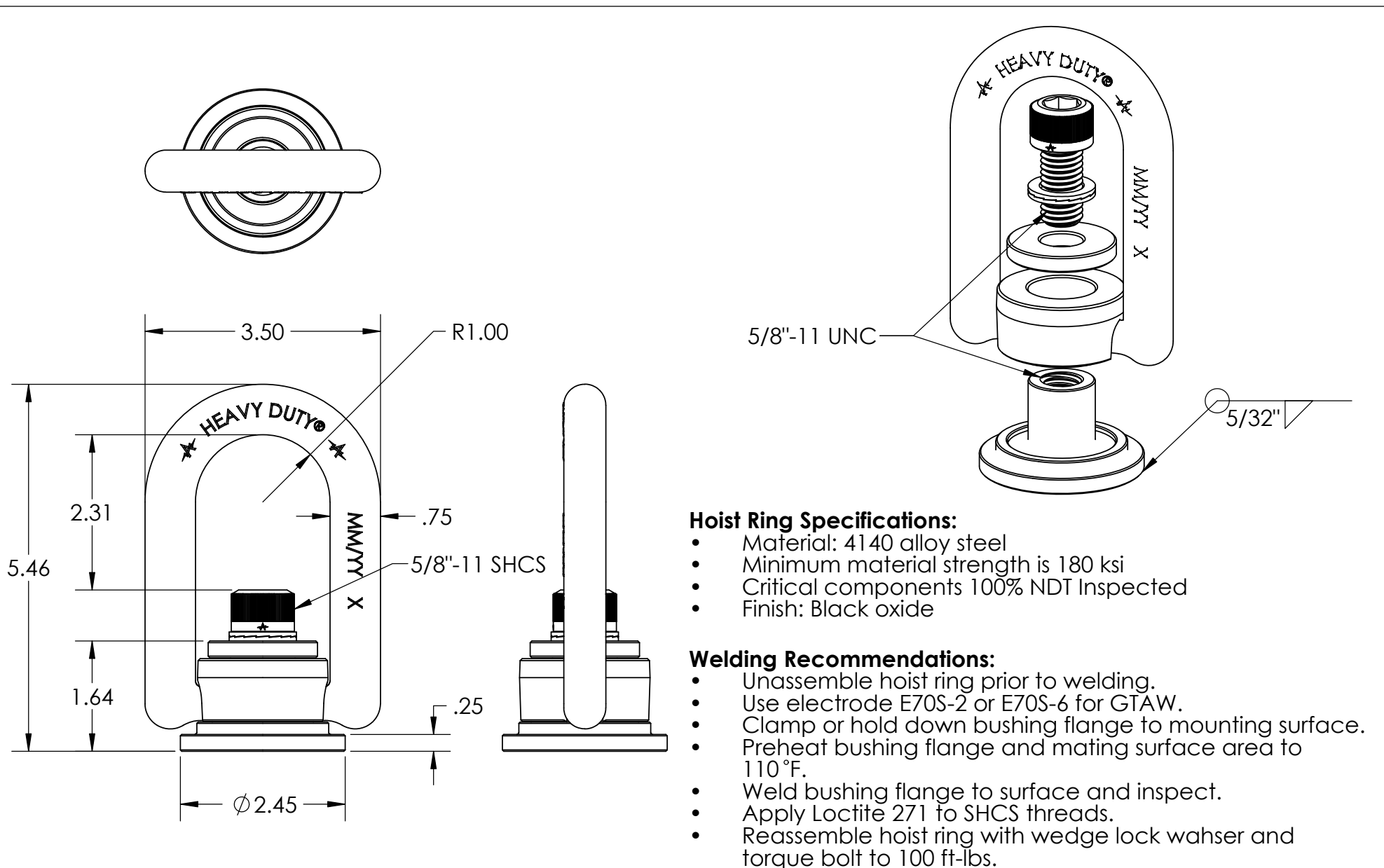

Hoist Ring Specifications:

- Material: 4140 alloy steel
- Minimum material strength is 180 ksi
- Critical components 100% NDT Inspected
- Finish: Black oxide

Welding Recommendations:

- Unassemble hoist ring prior to welding.
- Use electrode E70S-2 or E70S-6 for GTAW.
- Clamp or hold down bushing flange to mounting surface.
- Preheat bushing flange and mating surface area to 110°F.
- Weld bushing flange to surface and inspect.
- Apply Loctite 271 to SHCS threads.
- Reassemble hoist ring with wedge lock washer and torque bolt to 100 ft-lbs.

WORKING LOAD LIMIT: 5,000 lbs
 REQUIRED TORQUE: 100 ft-lbs

DIMENSIONS ARE FOR REFERENCE ONLY

FOR MORE INFORMATION
 VISIT OUR WEBSITE:
www.adbhoiststrings.com

YOU CAN ALSO CONTACT US AT:
 PHONE: (800) 423-4425
 FAX: (229) 253-8929
 EMAIL: adb@adbhoiststrings.com



PART DESCRIPTION		
Special Heavy Duty Weld Mount Hoist Ring		
SIZE	PART NO.	REV
A	X36640-PERMANENT INSTALLATION	-

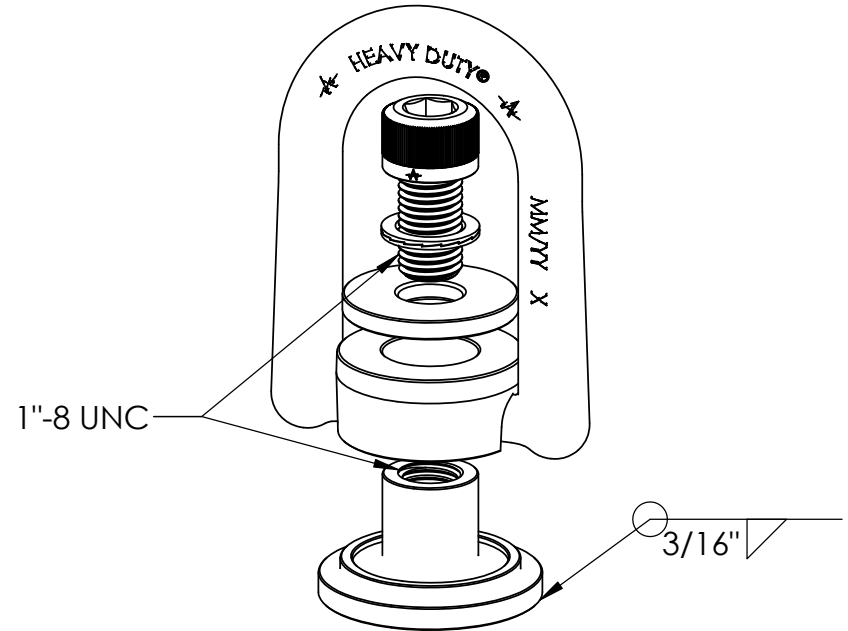
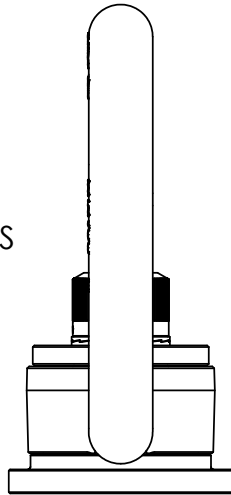
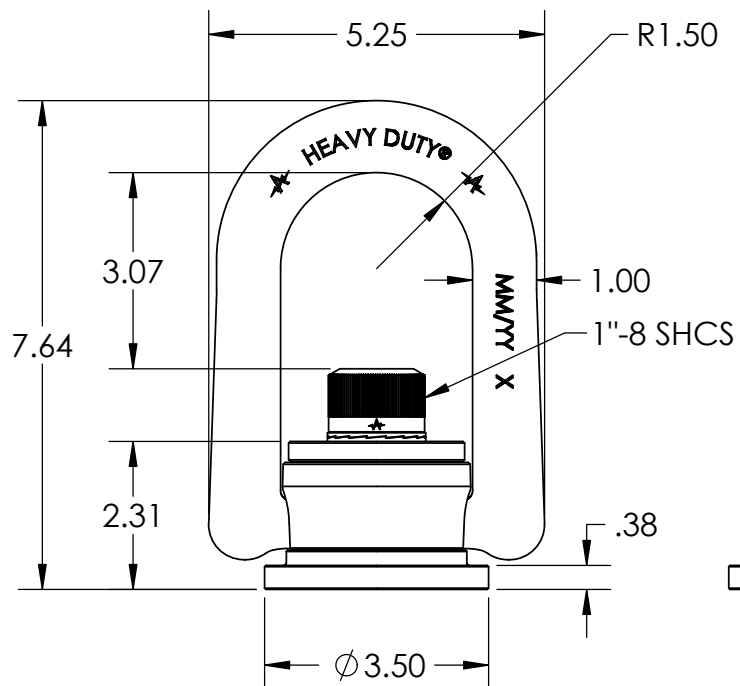
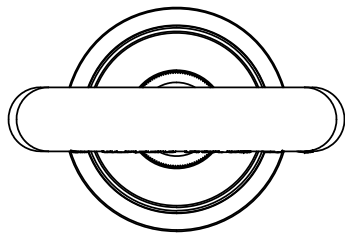

Hoist Ring Specifications:

- Material: 4140 alloy steel
- Minimum material strength is 180 ksi
- Critical components 100% NDT Inspected
- Finish: Black oxide

Welding Recommendations:

- Unassemble hoist ring prior to welding.
- Use electrode E70S-2 or E70S-6 for GTAW.
- Clamp or hold down bushing flange to mounting surface.
- Preheat bushing flange and mating surface area to 110°F.
- Weld bushing flange to surface and inspect.
- Apply Loctite 271 to SHCS threads.
- Reassemble hoist ring with wedge lock washer and torque bolt to 230 ft-lbs.

WORKING LOAD LIMIT: 10,000 lbs
 REQUIRED TORQUE: 230 ft-lbs

FOR MORE INFORMATION
 VISIT OUR WEBSITE:
www.adbhoiststrings.com

YOU CAN ALSO CONTACT US AT:
 PHONE: (800) 423-4425
 FAX: (229) 253-8929
 EMAIL: adb@adbhoiststrings.com



PART DESCRIPTION
 Special Heavy Duty
 Weld Mount Hoist Ring

SIZE	PART NO.	REV
A	X36645-PERMANENT INSTALLATION	-

DIMENSIONS ARE FOR REFERENCE ONLY

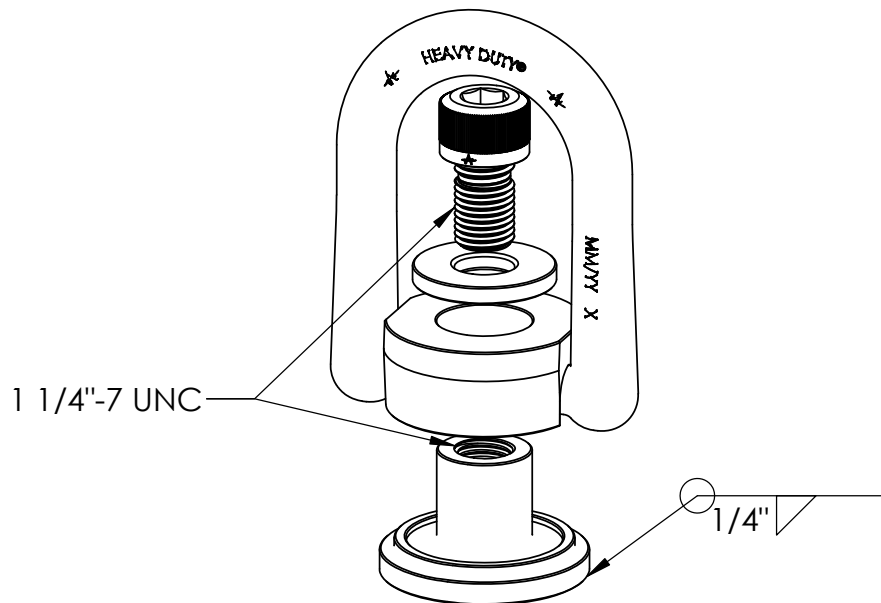
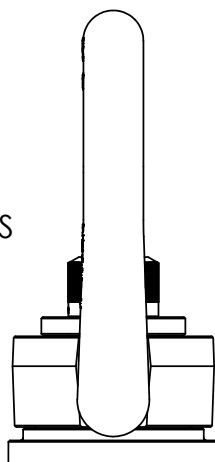
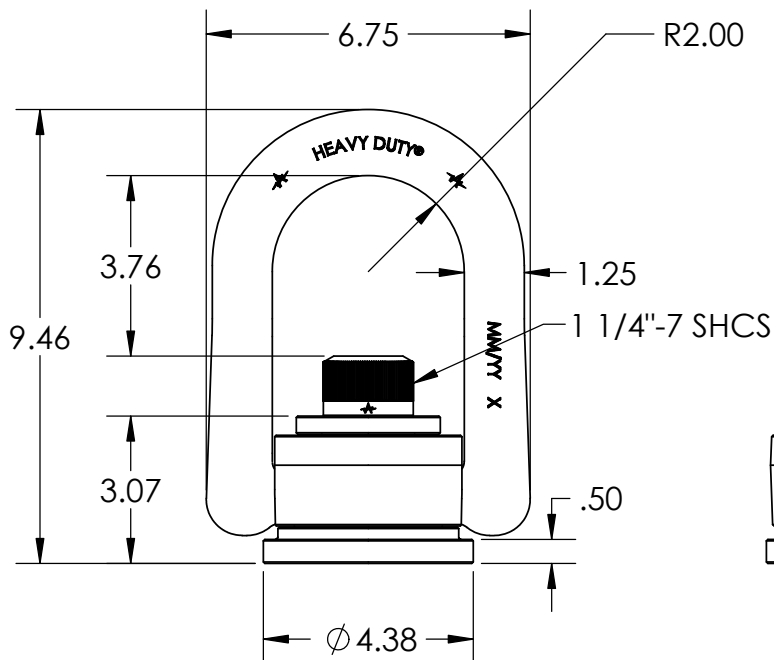
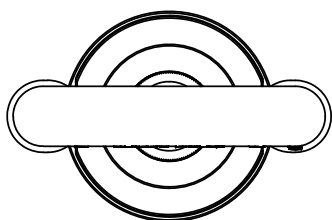

Hoist Ring Specifications:

- Material: 4140 alloy steel
- Minimum material strength is 180 ksi
- Critical components 100% NDT Inspected
- Finish: Black oxide

Welding Recommendations:

- Unassemble hoist ring prior to welding.
- Use electrode E70S-2 or E70S-6 for GTAW.
- Clamp or hold down bushing flange to mounting surface.
- Preheat bushing flange and mating surface area to 110°F.
- Weld bushing flange to surface and inspect.
- Reassemble hoist ring and torque bolt to 800 ft-lbs.

WORKING LOAD LIMIT: 24,000 lbs
 REQUIRED TORQUE: 800 ft-lbs

FOR MORE INFORMATION
 VISIT OUR WEBSITE:
www.adbhoiststrings.com

YOU CAN ALSO CONTACT US AT:
 PHONE: (800) 423-4425
 FAX: (229) 253-8929
 EMAIL: adb@adbhoiststrings.com



PART DESCRIPTION
 Heavy Duty Weld Mount
 Hoist Ring

SIZE	PART NO.	REV
A	36650	-

DIMENSIONS ARE FOR REFERENCE ONLY