

ELECTRICAL DATA

MOTOR	HP/KW	RLA	LRA
BLOWER	10HP	11.6A	81A
COMP 1&2	20HP	31A	225A
C/FAN 1&2	2HP	4.0A	25A
HEATER 1&2	48kW	60A	-

UNIT DATA

FLA	141.6A
MCA	164A
MFS	200A

SET POINTS

1HP	560#/MANUAL RESET
2HP	350#/CUT IN/295# CUT-OUT
1LP	65#/MANUAL RESET
1TR, 2TR, 3TR	60 SEC
1CB-OL, 3CB-OL	3BA
5OL	12A
7OL, 8OL	70A
IR33 SETTINGS	
IR33-1 (CLG)	70F (BY RA PROBE) 55F (BY SA PROBE)
IR33-2 (HTG)	78F (BY RA PROBE) 95F (BY SA PROBE)

LEGEND

- AFS - AIR FLOW SWITCH
- CB - CIRCUIT BREAKER
- CO - CONVENIENT OUTLET
- CR - CONTROL RELAY
- ES - EMERGENCY SWITCH
- FLA - FULL LOAD AMPS
- FU - FUSE
- GFCI - GROUND FAULT CIRCUIT INTERRUPTOR
- HP - HORSE POWER
- HP - HIGH PRESSURE SWITCH
- HTL - HIGH TEMPERATURE LIMIT
- ITS - INTERNAL THERMAL SENSOR
- J - JUMPER
- KW - KILOWATT
- L.L.S - LIQUID LINE SOLENOID
- LRA - LOCKED ROTOR AMPS
- LP - LOW PRESSURE SWITCH
- M - CONTACTOR
- MP - MOTOR PROTECTOR
- MCA - MINIMUM CIRCUIT AMPS
- MCCB - MOULDED CASE CIRCUIT BREAKER
- MFS - MAXIMUM FUSE SIZE
- OL - OVERLOAD PROTECTOR
- PL - PILOT LIGHT
- PMR - PHASE MONITOR RELAY
- POT - POTENTIOMETER
- RLA - RATED LOAD AMPS
- STG - STAGE
- SW - SWITCH
- TB - TERMINAL BLOCK
- TR - TIMER RELAY
- T - TRANSFORMER
- TS - TEMP. SENSOR
- R - RED
- G - GREEN
- A - AMBER
- VFD - VARIABLE FREQ. DRIVE
- * - FIELD SUPPLY
- ▲ - MANUAL RESET
- - FACTORY WIRING
- - - - - FIELD WIRING
- △ - SEE NOTE 'n'
- - CAM-LOCK

CABLE SIZE

- CONTROL - 14AWG
- (A) - 6AWG, BLACK
- (B) - 10AWG, BLACK
- (C) - 12AWG, BLACK
- (D) - 3x10AWG, BLACK
- (E) - 4AWG, BLACK

						THIS DOCUMENT IS THE PROPERTY OF SMARTECH AND SHOULD NOT BE DISCLOSED OR USED WITHOUT THE EXPRESSED CONSENT OF COMPANY		PROJECT: 19100 40TONS RENTAL AC WITH HEAT			
						DRAWN BY: JUN DATE: 05.12.2016		MODEL: SACP 40TA-HS		TITLE: SCHEMATIC WIRING DIAGRAM	
						CHECKED BY: [Signature] DATE:		UNIT NO.: -		DRAWING NO.: S210840183 F.O NO.: SBG 500197	
						APPROVED BY: [Signature] DATE: 5/17/2016		SHEET 1 OF 4		SMI/MFG/ENG/FM/02(REV1)	
REV.	DESCRIPTION	DATE	REV. BY	CHK'D. BY	APP'D BY						

115VAC
CONTROL VOLTAGE

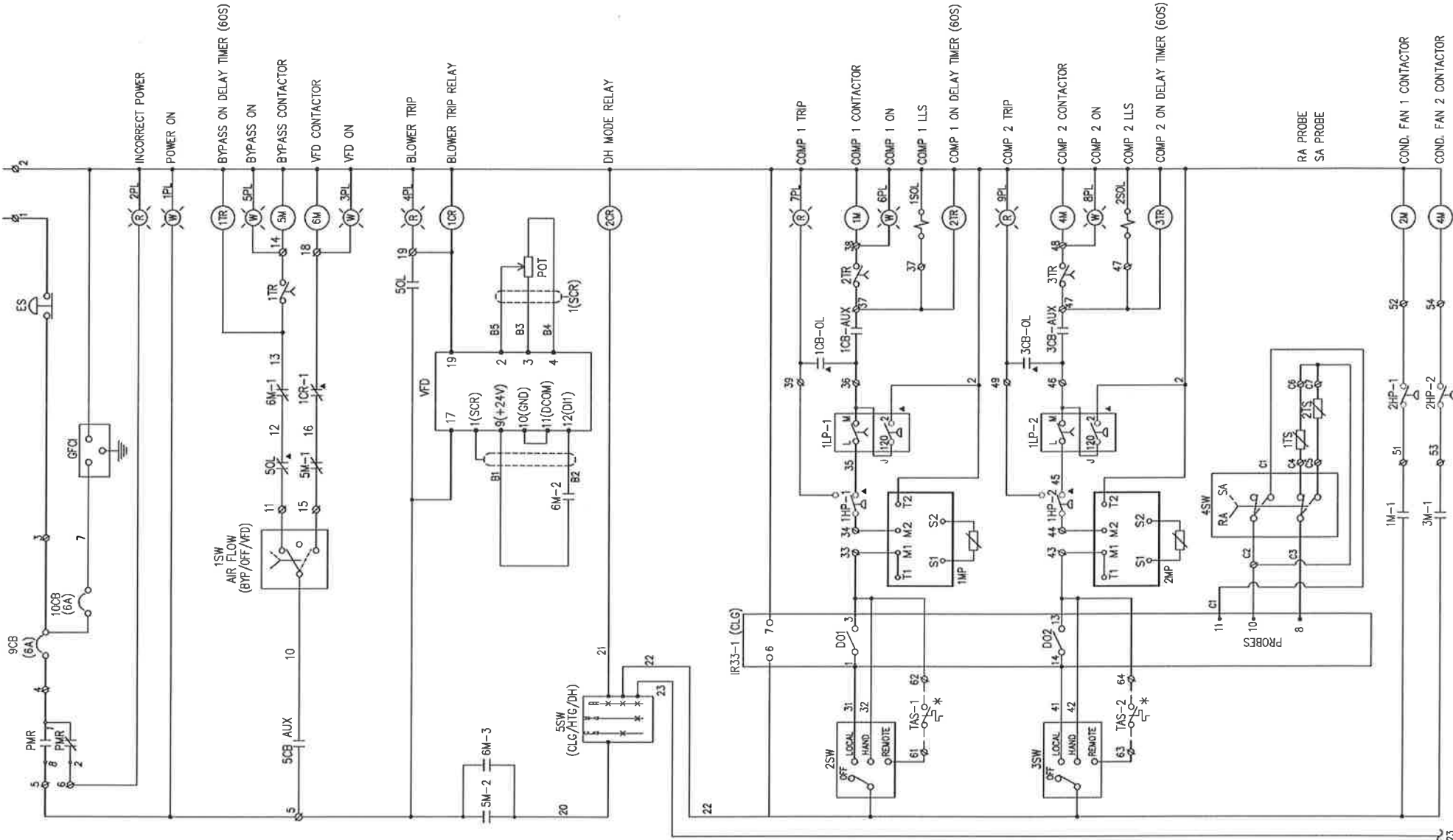

REV.	DESCRIPTION	DATE	REV. BY	CHK'D. BY	APP'D BY

THIS DOCUMENT IS THE PROPERTY OF SMARTECH AND SHOULD NOT BE DISCLOSED OR USED WITHOUT THE EXPRESSED CONSENT OF COMPANY

DRAWN BY: JUN DATE: 05.12.2016

CHECKED BY: DATE: / /

APPROVED BY: DATE: / /

PROJECT: 19100 40TONS RENTAL AC WITH HEAT

MODEL: SACP 40TA-HS

UNIT NO: -





SMART FAMILY OF COOLING PRODUCTS
www.SmartCoolingProducts.com 281-540-2805

TITLE: SCHEMATIC WIRING DIAGRAM

DRAWING NO: S210840183 F.O NO: SEC 500197

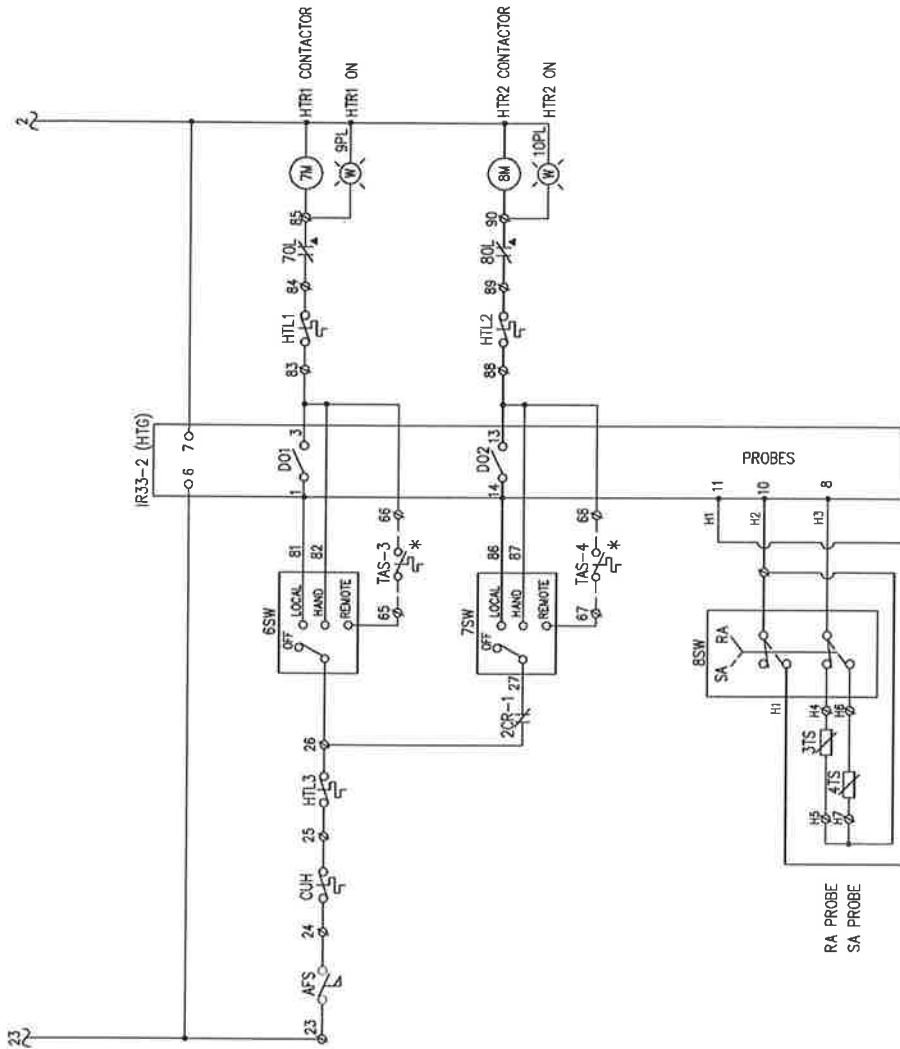
SHEET 2 OF 4



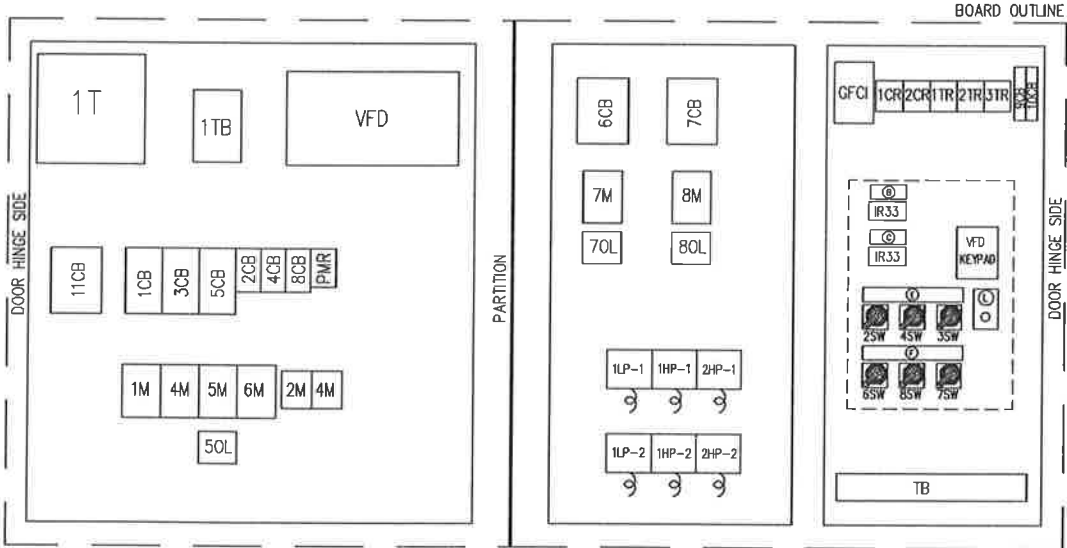
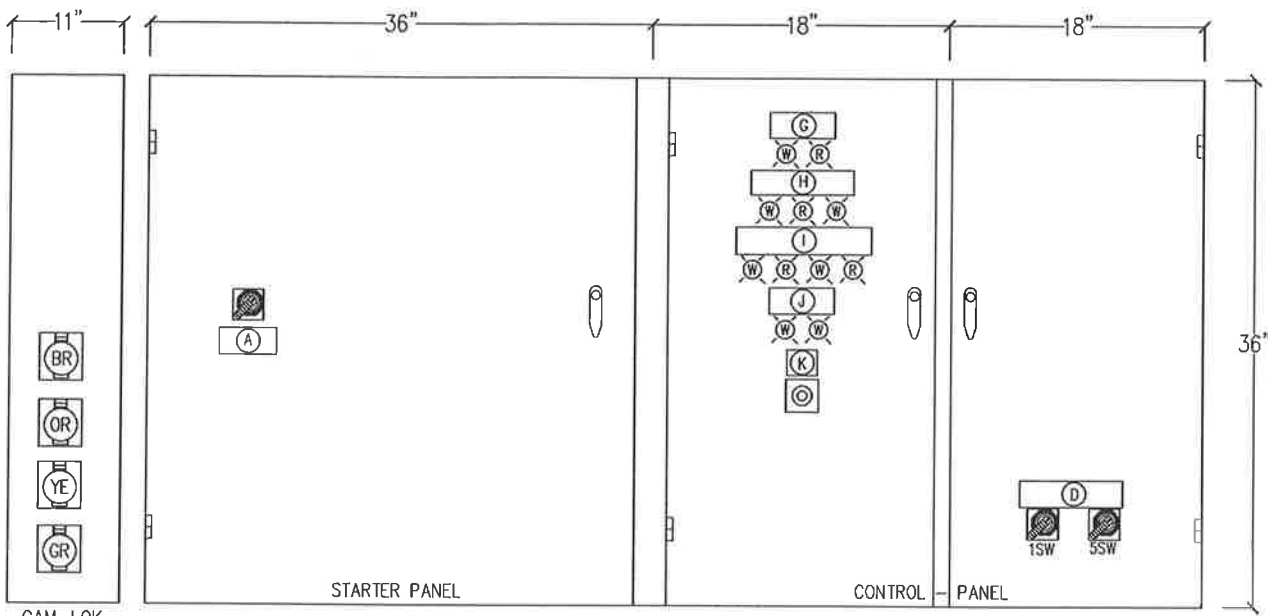

REV.	DESCRIPTION	DATE	REV. BY	CHK'D. BY	APP'D BY	APPROVED BY:	DATE:	THIS DOCUMENT IS THE PROPERTY OF SMARTECH AND SHOULD NOT BE DISCLOSED OR USED WITHOUT THE EXPRESSED CONSENT OF COMPANY	PROJECT: 19100 40TONS RENTAL AC WITH HEAT	 SMART FAMILY OF COOLING PRODUCTS <small>www.SmartCoolingProducts.com 281-540-2805</small>
								DRAWN BY: JUN	DATE: 05.12.2016	
										DRAWING NO: S210840183
										F.O NO: SEC 500197
										SHEET 3 OF 4

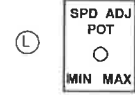

TAGS: -

- (A) MAIN CIRCUIT BREAKER
- (B) IR33-1 CLG
- (C) IR33-2 HTG
- (D) AIR FLOW MODE VFD OFF BYP CLG HTG DH
- (E) COMPRESSOR1 CLG PROBE SELECTION COMPRESSOR2
- (F) HEATER 1 HTG PROBE SELECTION HEATER 2
- (G) CONTROL POWER ON INCORRECT POWER
- (H) VFD RUNNING BLOWER TRIP BYPASS RUNNING
- (I) COMPRESSOR1 COMPRESSOR1 COMPRESSOR2 COMPRESSOR2 RUNNING TRIP RUNNING TRIP
- (J) HEATER1 ON HEATER2 ON
- (K) EMERGENCY STOP



						THIS DOCUMENT IS THE PROPERTY OF SMARTECH AND SHOULD NOT BE DISCLOSED OR USED WITHOUT THE EXPRESSED CONSENT OF COMPANY		PROJECT: 19100 40TONS RENTAL AC WITH HEAT			
						DRAWN BY: JUN	DATE: 05.12.2016	MODEL: SACP 40TA-HS			
						CHECKED BY:	DATE:	UNIT NO:		DRAWING NO: S210840183	
REV.	DESCRIPTION	DATE	REV. BY	CHK'D. BY	APP'D BY	APPROVED BY:	DATE: 5/12/2016			F.O NO: SRG 500197	
										SHEET 4 OF 4	