

NOTE:

1. ALL DIMENSION TOLERANCE $\pm 1/2"$ UNLESS SPECIFIED
2. HOT DIPPED GALVANIZED TUBULAR BASE & FRAME (PAINTED BLACK)
3. FORK POCKETS TOLERANCE
 - i) HEIGHT ; $3.75" + 0.25"/- 0.00"$
 - i) LENGTH ; $10" + 0.25"/- 0.00"$
4. FRAME WITH TUBULAR GUSSETS
5. FULL SEAL TYPE WELDS

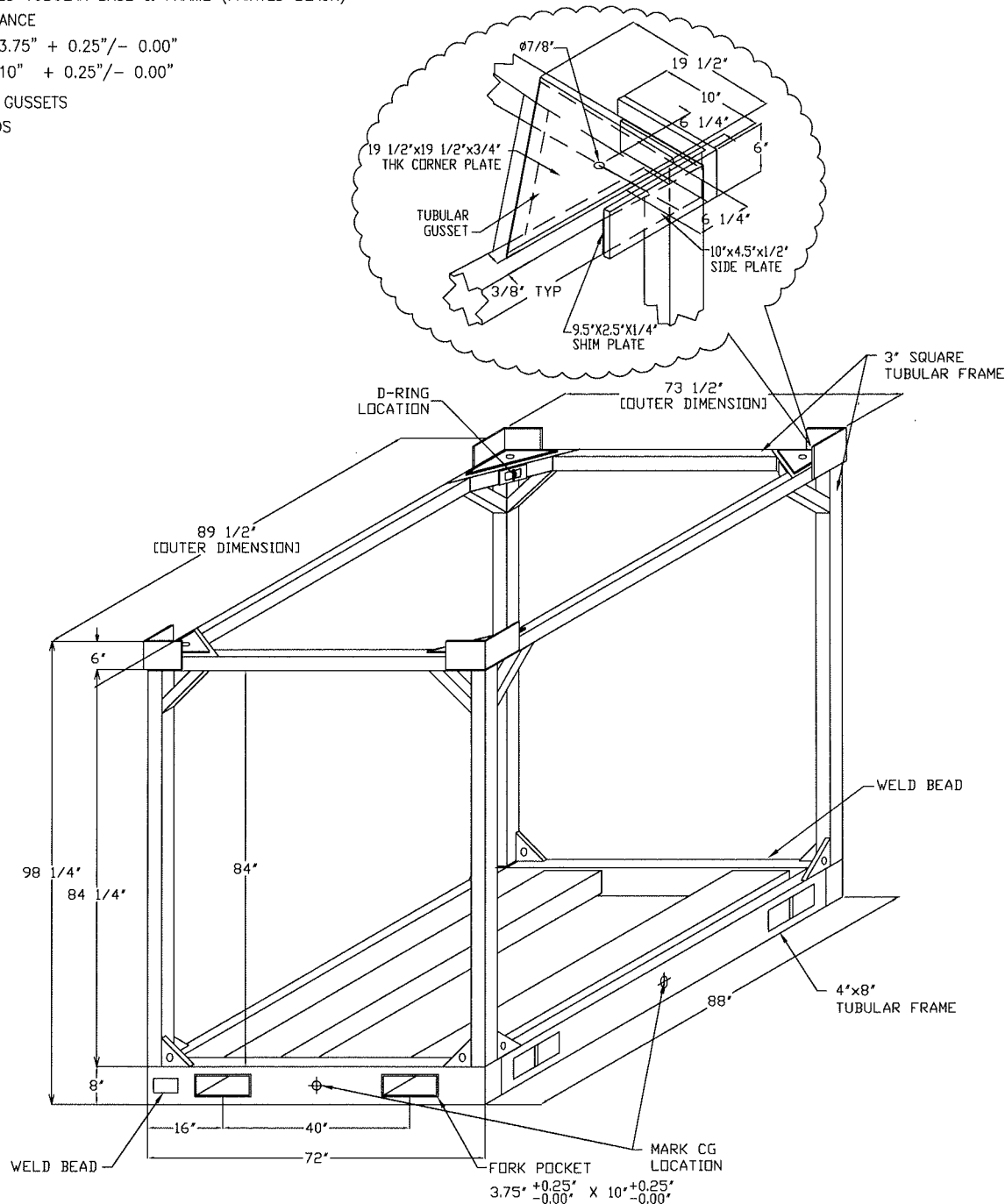

CERTIFIED DRAWING

ALL DIMENSIONS ARE IN INCHES UNLESS OTHERWISE SPECIFIED.

| | | | |
|-------------|------------|------|------------|
| DRAWN BY | ANG | DATE | 30/11/2016 |
| CHECKED BY | <i>DJL</i> | DATE | 5/12/16 |
| APPROVED BY | <i>EP</i> | DATE | 5/10/16 |

| REV | DESCRIPTION | DATE | REV BY | CHK'D BY | APP'D BY |
|-----|-------------|------|--------|----------|----------|
| | | | | | |

SMART FAMILY OF COOLING PRODUCTS
www.SmartCoolingProducts.com 281-540-2805

THIS DOCUMENT IS THE PROPERTY OF SMARTTECH AND SHOULD NOT BE DISCLOSED OR USED WITHOUT THE EXPRESSED CONSENT OF COMPANY

PROJECT 19096
F/O :

MODEL SACP 20A-HS

TITLE
AIR COOLED PACKAGED

DRAWING NO S110840195-01

| | | | |
|----|---------------|-------|----|
| A4 | SCALE : N.T.S | SHEET | OF |
|----|---------------|-------|----|